

UMS Portable Injection Units U.S. Patent 6,994,810 B2

W188 N11707 Maple Road  
 Germantown, WI 53022 USA  
 Phone: (262) 255-5790  
 Fax: (262) 255-7206  
 E-Mail: [contact@mgstech.com](mailto:contact@mgstech.com)

[www.mgstech.com](http://www.mgstech.com)  
[www.multishot.com](http://www.multishot.com)

## MOUNTING OPTION 1

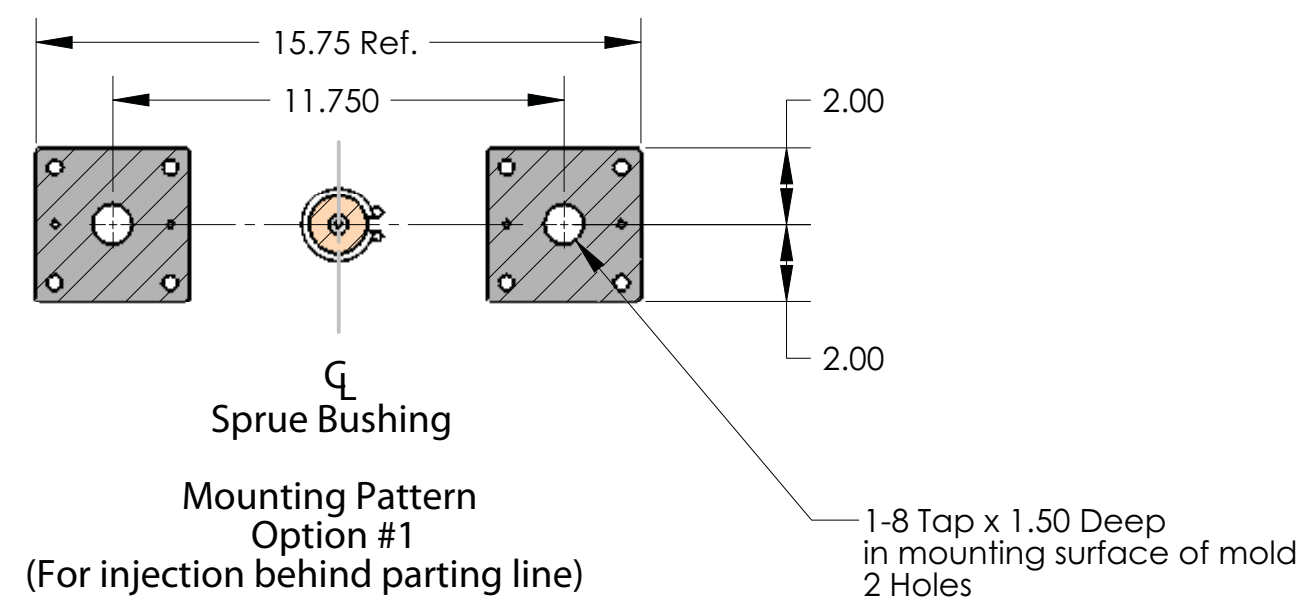

Option #1 requires sprue bushing to be located a minimum of 2.062" from the parting line.

SECTION A-A

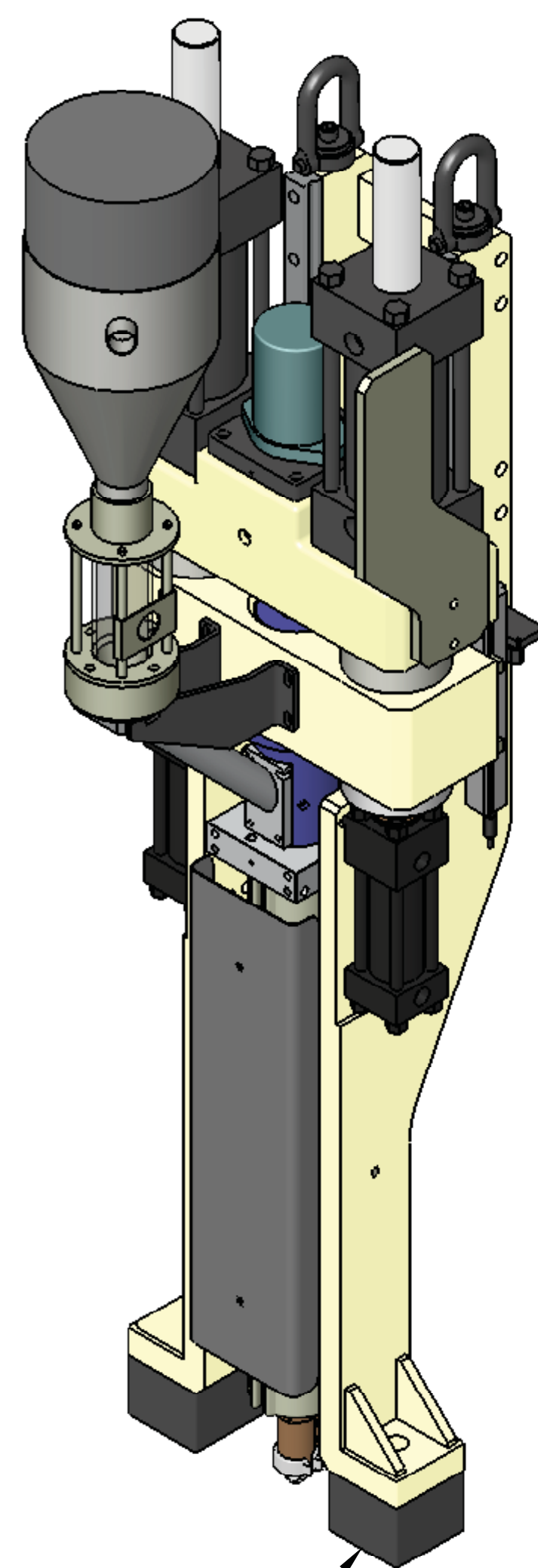
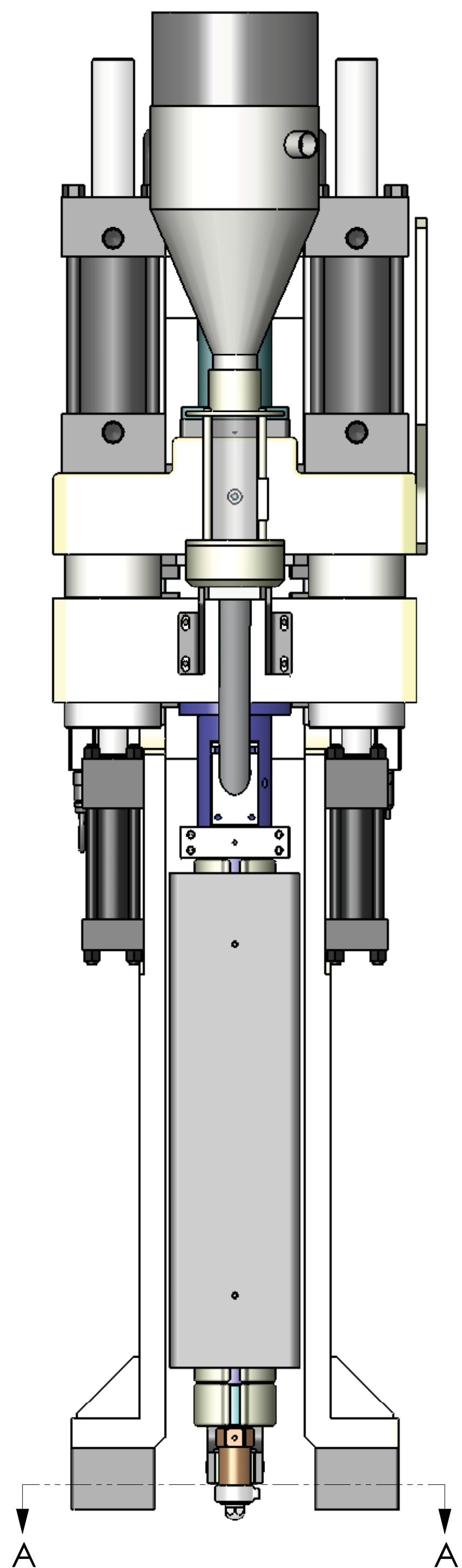

Inline Riser (Option 1)

## MOUNTING OPTION 2

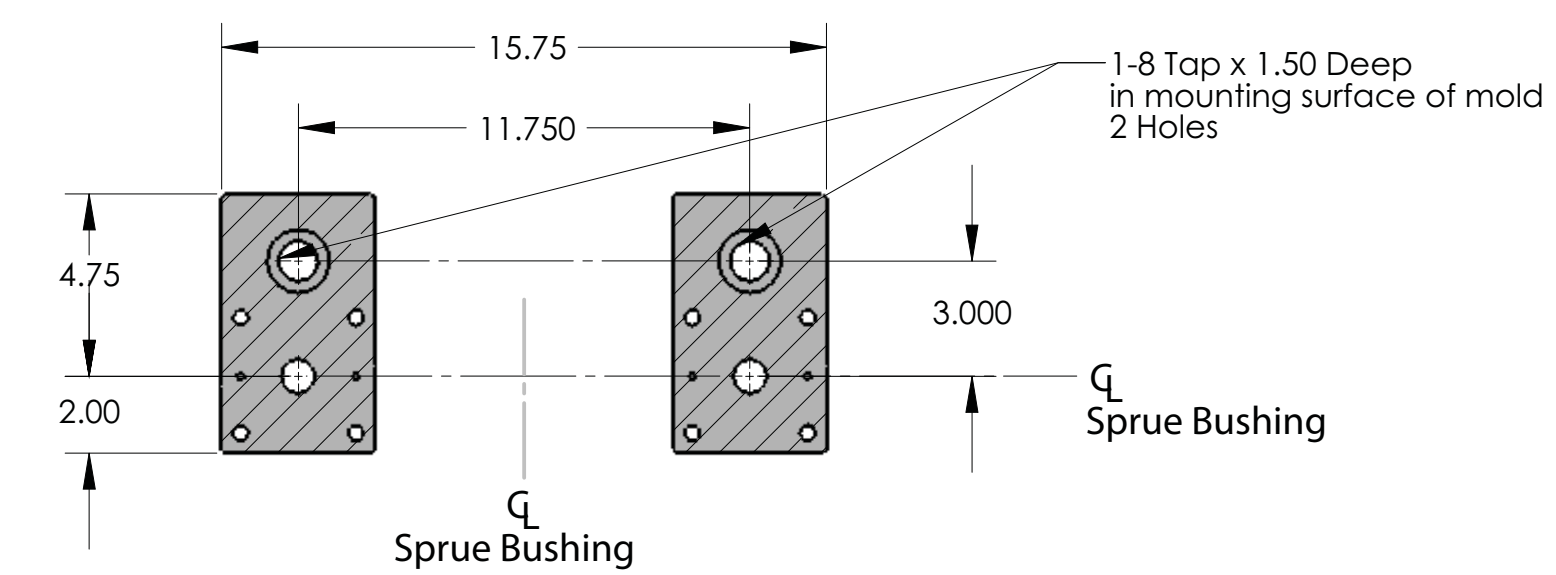

SECTION B-B

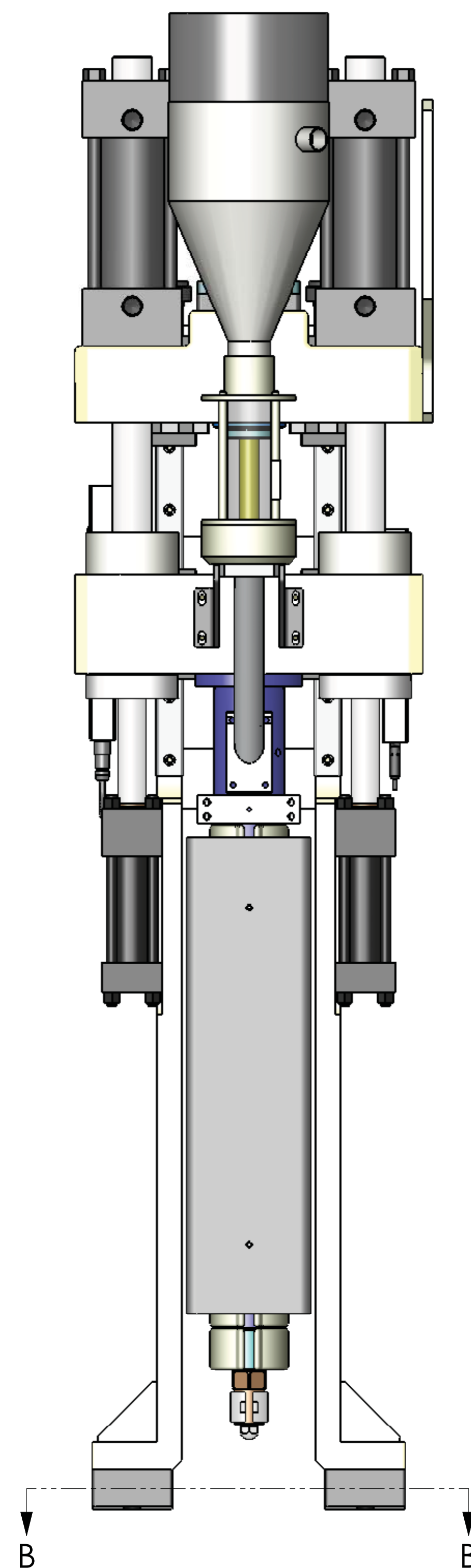

Offset Riser Relieved for parting line injection (Option 2)

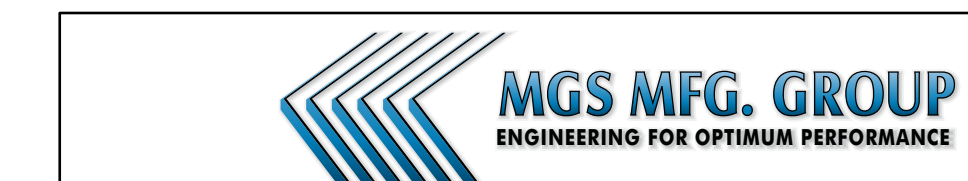

UMS Portable Injection Units U.S. Patent 6,994,810 B2

W188 N11707 Maple Road  
Germantown, WI 53022 USA  
Phone: (262) 255-5790  
Fax: (262) 255-7206  
E-Mail: contact@mgstech.com

www.mgstech.com  
www.multishot.com