

UMS Portable Injection Units U.S. Patent 6,994,810 B2

W188 N11707 Maple Road
 Germantown, WI 53022 USA
 Phone: (262) 255-5790
 Fax: (262) 255-7206
 E-Mail: contact@mgstech.com

www.mgstech.com
www.multishot.com

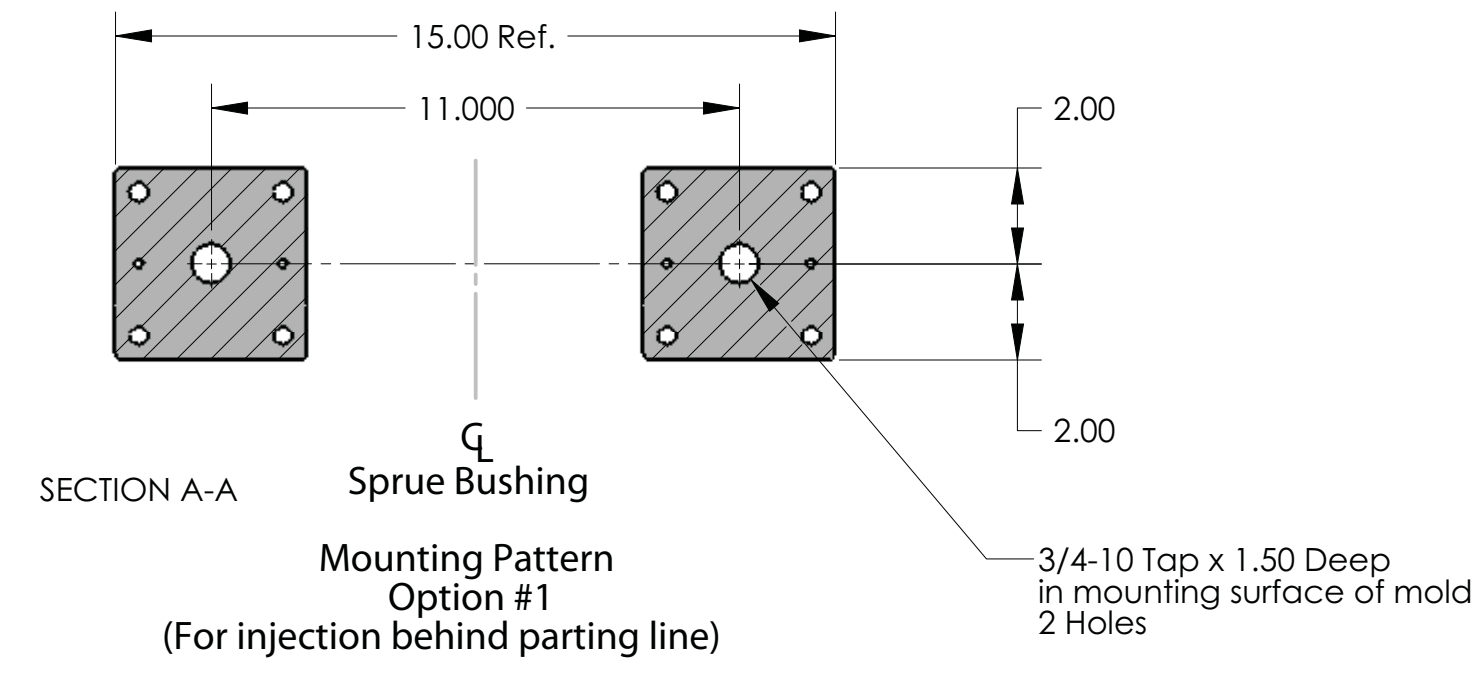

Option #1 requires sprue bushing to be located a minimum of 2.062" from the parting line.

MOUNTING OPTION 1

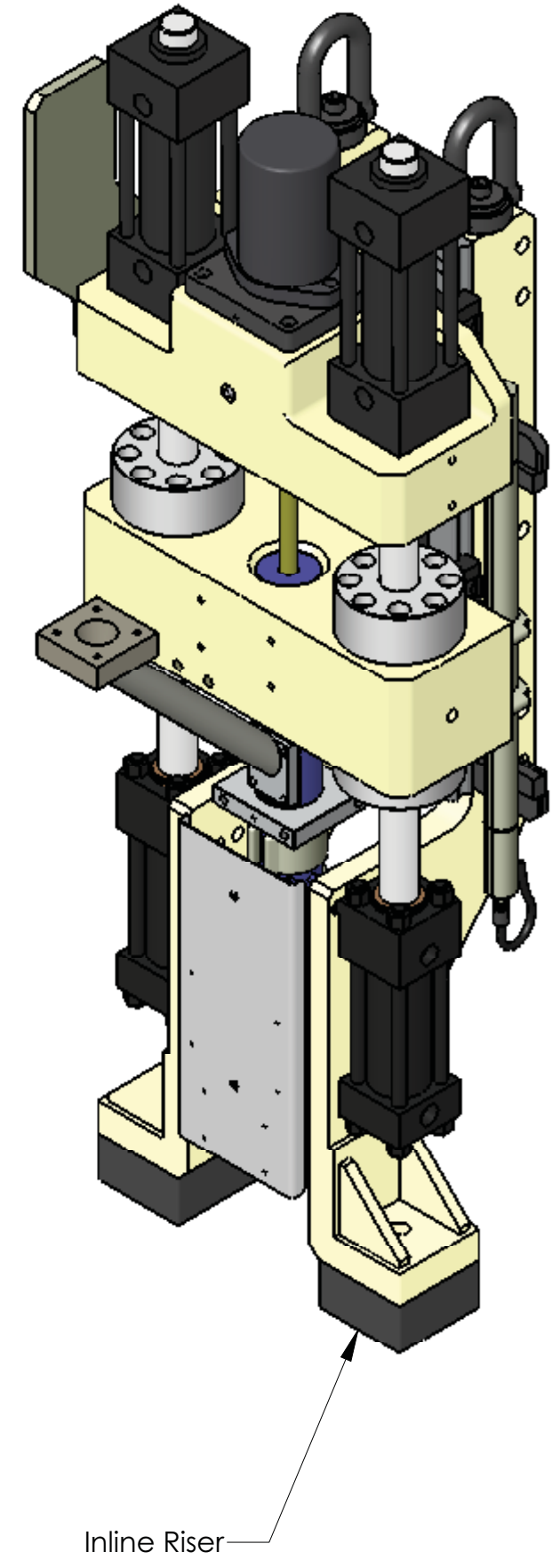
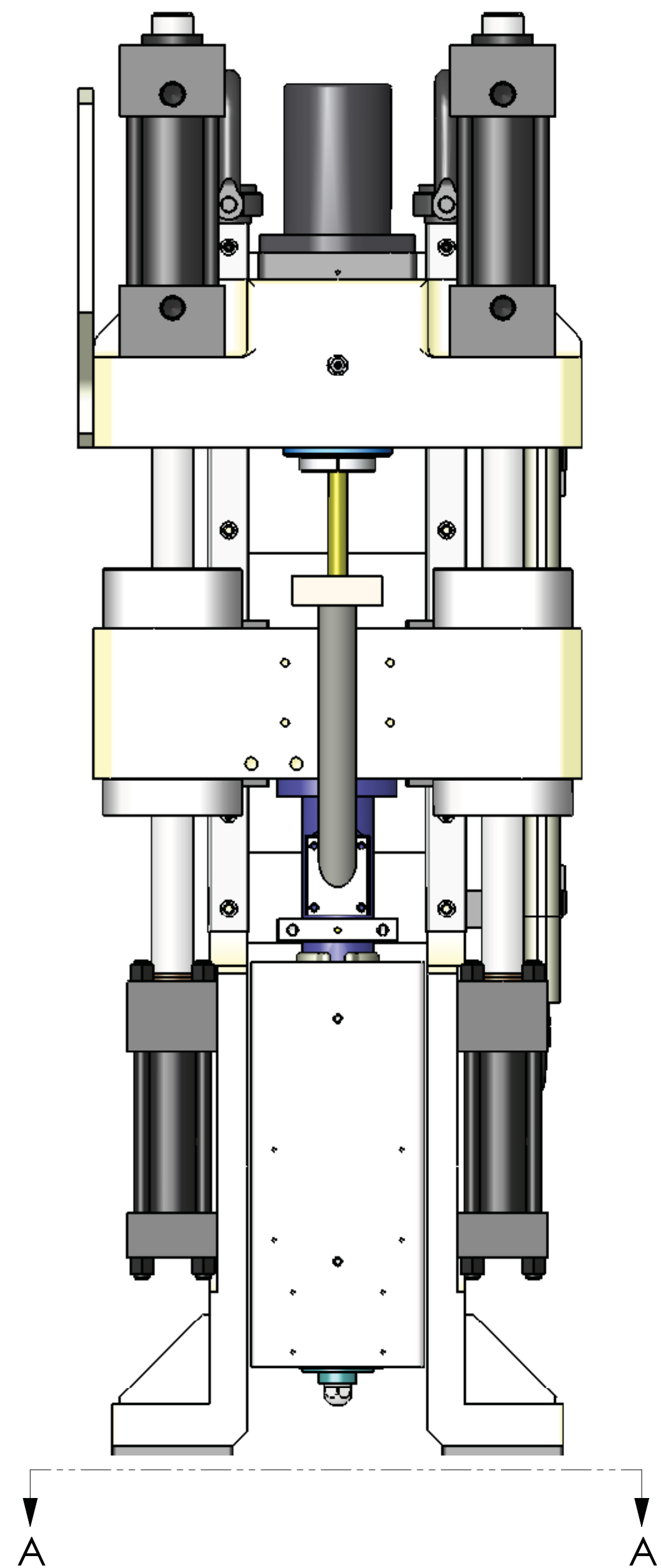

MOUNTING OPTION 2

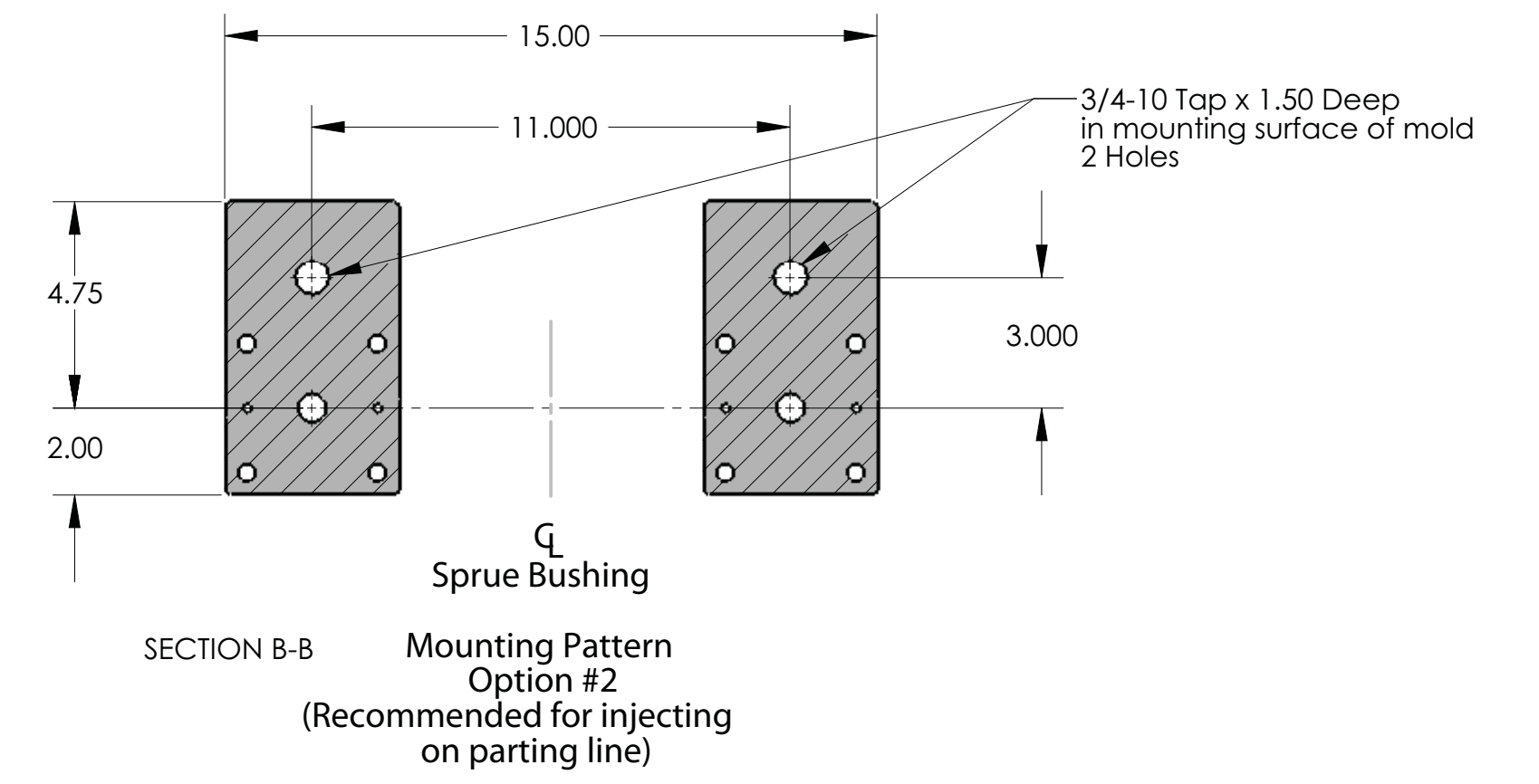

(Recommended for injecting on parting line)

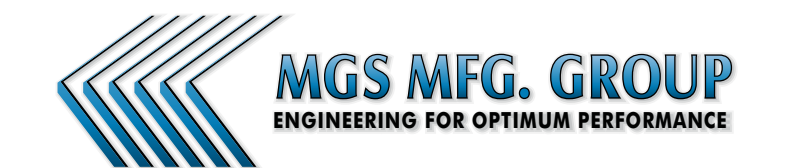
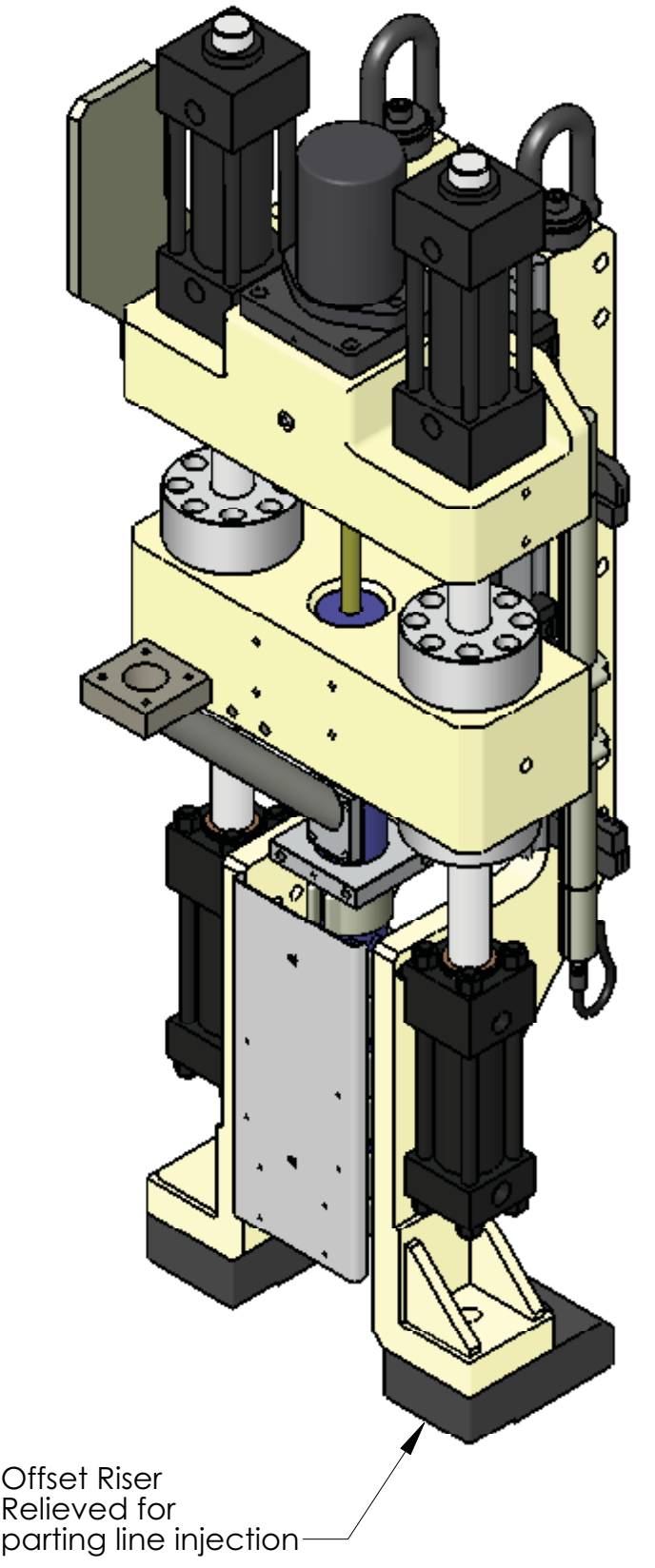
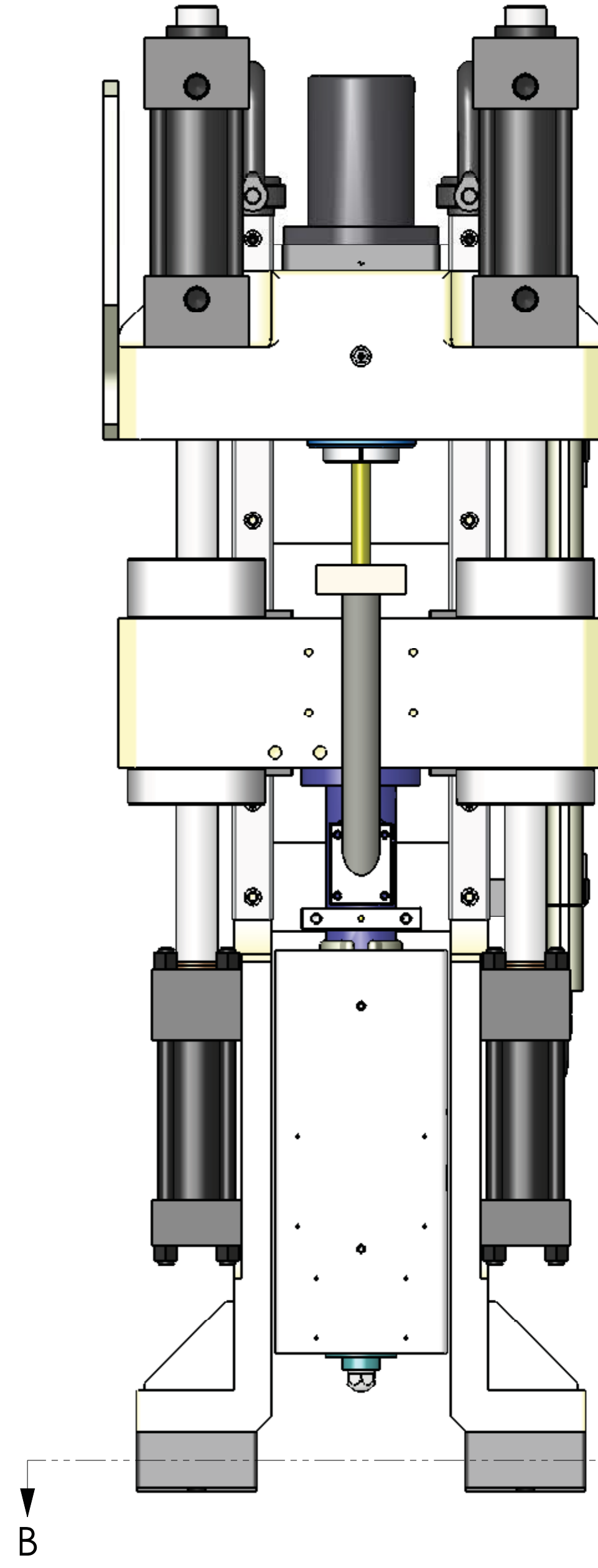

UMS Portable Injection Units U.S. Patent 6,994,810 B2

W188 N11707 Maple Road
 Germantown, WI 53022 USA
 Phone: (262) 255-5790
 Fax: (262) 255-7206
 E-Mail: contact@mgstech.com

www.mgstech.com
 www.multishot.com